

artist of light



Specification

For LED Neon Flex Ribbon

LF10B



Table of Contents

Introduction	03
1. Specifications & Parameters	04
1.1 Dimensions of Light	
1.2 Technical Parameters	
1.3 Optical Parameters	
2. Functions & Features	05
2.1 Product Features	
2.2 Minimum Bend Diameter	
3. Types of Connector	05
3.1 Injection-Moulded Connector	
3.2 Clasp Connector	
3.3 Snap Connector	
4. Mounting Profile	07
4.1 Locking Aluminum Profile	
4.2 Plastic Profile	
4.3 Self-locking Aluminum Profile	
5. Packaging	09
6. Appendix	10
6.1 Third-Party Test Report	
6.2 Reliability Test of Light	
6.3 Certificate	
6.4 Figures of Typical Characteristics	
6.5 (X,Y) Chromaticity Diagram	
6.6 Wavelength of Color Light	
6.7 Loading Chart	
6.8 Correlated Color Temperature	

Introduction

LF10B is a member of the Artist of Light series with smallest smooth flat exterior that allows the most flexible and adaptable manipulations for visually appealing shapes and produces superior homogenized illumination along its full length.

Built-in protection circuit design which means single LED failure has no effect on other LEDs working in the same unit and the whole light can keep constant lighting.

LF10B is UL/cUL, CE, TUV and RoHS compliant. Moreover, it has passed environmental resistance, optical, mechanical and electrical tests in our lab under the support of advanced experimental equipments and technology to ensure it meets the requirements of harsh environments. Also it has passed relevant tests of third party inspection authority.

Fully encapsulated in the flexible PVC chamber by utilizing consummate extrusion technology, assembled with multiple patented connectors to achieve IP68 protection, easy for installation and applicable for various circumstances.

C-FR-F10B features excellent luminous efficacy, solid illumination, and ultra flexibility with small bend diameter in curve bending shape.

Applications:

1. Outdoor or Indoor Contour/Border Lighting
2. Architectural Outline/Decorative Lighting
3. Cove/Accent Lighting
4. Facade/Floor Lighting
5. Signage/Guide Lighting

1. Specifications & Parameters

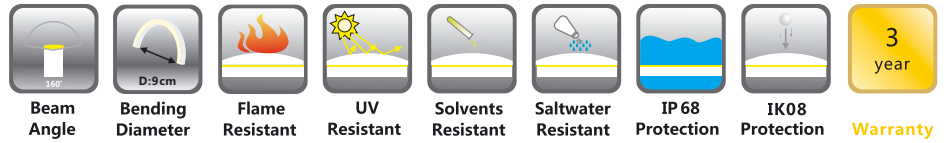

1.1 Dimensions of Light

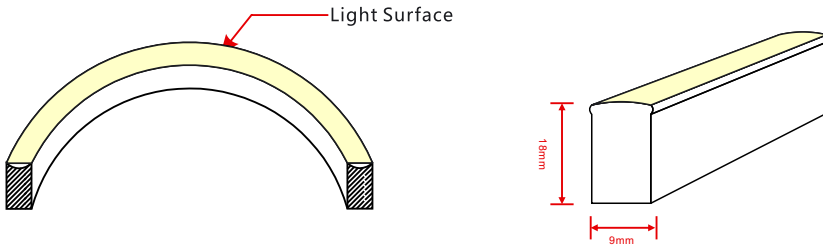

Note: Unless otherwise stated, the tolerance of the light is $\pm 0.3\text{mm}$.

1.2 Technical Parameters

Technical Parameters

Article No.	LF10B-D24CV	LF10B-D24CV	LF10B-D12CV
Color	Red/Amber	Green/Blue/White	Red/Amber/Green/Blue/White
Working Voltage	DC24V	DC24V	DC12V
Rated Power/mtr	3.5W	4.5W	4.5W
LED Qty/mtr	72	72	72
LED Distance	13.89mm	13.89mm	13.89mm
Min. Cutting Unit	9LEDs(1unit)	6LEDs(1unit)	3LEDs(1unit)
Min. Cutting Length	12.5cm(1unit)	8.33cm(1unit)	4.17cm(1unit)
Continuous Length	20m	15m	7.5m
Weight/m	210g		
Storing Temp.	-20 ~ 60°C		
Working Temp.	-20 ~ 45°C		
Operating Temp.	0 ~ 45°C		
IP Rating	IP68		



1.3 Optical Parameters

Photometric Data

Article No.	LF10B				
LED Type	SMD				
Beam angle	160°				
Color	Wavelength	Lumen/m	Color	CCT	Lumen/m
Red	620-630nm	>45lm	2400K	2400±125K	>110lm
Green	520-530nm	>80lm	2700K	2725±145K	>110lm
Blue	465-475nm	>15lm	3000K	3045±175K	>120lm
Amber	585-595nm	>50lm	3500K	3465±245K	>120lm
			4000K	3985±275K	>120lm
			4500K	4503±243K	>120lm
			5000K	5028±283K	>120lm
			5700K	5665±355K	>110lm
			6500K	6530±510K	>110lm

Candle power distribution

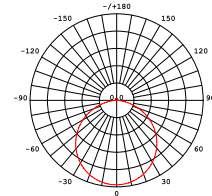

Illuminance Characteristics

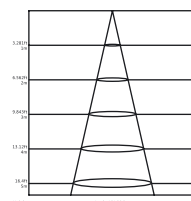

2. Functions & Features

2.1 Product Features

1. High quality and high brightness SMD LED chip.
2. Protection Circuit: Each LED Protected.
3. Variety of monochromatic lights for option including Red, Green, Blue, Amber and White light(2700K to 6500K).
4. UV & flame resistant construction(PVC).
5. Flat profile, good choice for recessed mounting.
6. High color consistency & smooth illumination with invisible light dots.
7. Ultra flexible with 90mm minimum bending diameter.
8. Easy installation and assembly with DIY accessories for joining and terminating.
9. High IP rating(IP68).
10. The product IP rate is ultimately in line with properly applied IP rated connectors.
11. Continuous length up to 20m (R, A) / 15m (G, B, W) by powering one end.
12. Environmentally friendly & energy efficient.
13. Automated production, high reliability & long warranty.
14. 5 years life span (Do not continuously operate over 8 hours per day).

2.2 Minimum Bend Diameter

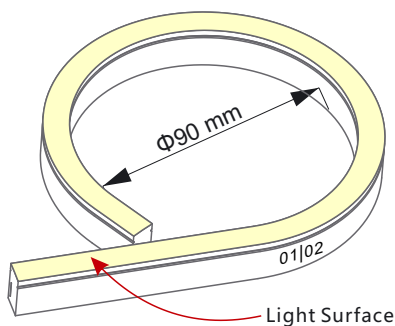

The light can only be bent laterally (opposite bend along to light surface).

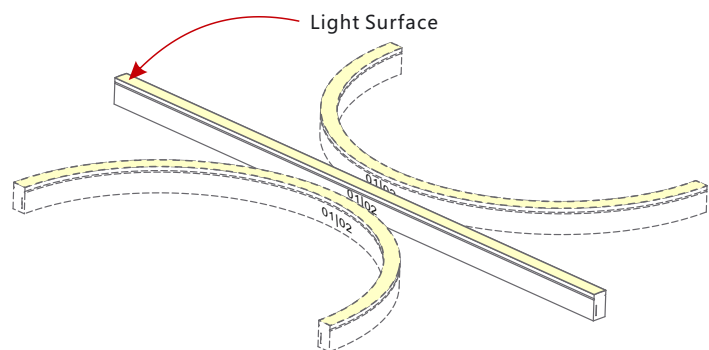

Do not bend smaller than allowed minimum bend diameter.

3. Types of Connector

3.1 Injection-moulded Connector

Note: Unless otherwise stated, the tolerance of the connector is $\pm 0.5\text{mm}$.



Injection-moulded Front Connector (bottom)

Connects light to power supply with pre-installed bottom feed cable, IP68. Cable length available in 0.3m, 1m, 3m, 5m, 10m, 15m, 20m.

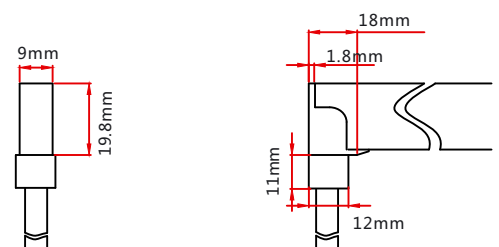

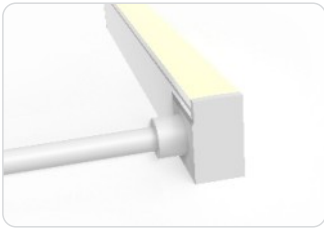

Injection-moulded Front Connector (side)

Connects light to power supply with pre-installed side feed cable, IP68. Cable length available in 0.3m, 1m, 3m, 5m, 10m, 15m, 20m.

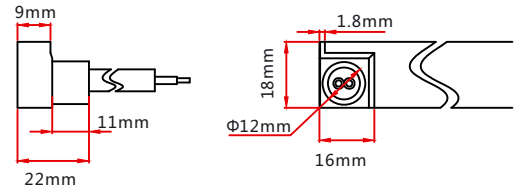

Injection-moulded Front Connector (top end)

Connects light to power supply with pre-installed end feed cable, IP68. Cable length available in 0.3m, 1m, 3m, 5m, 10m, 15m, 20m.

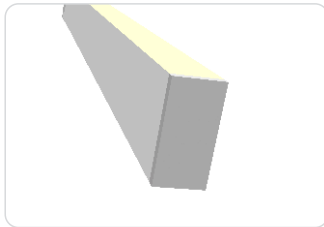
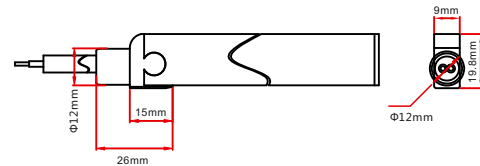

Injection-moulded End Cap

Pre-installed termination protection of the light, IP68.

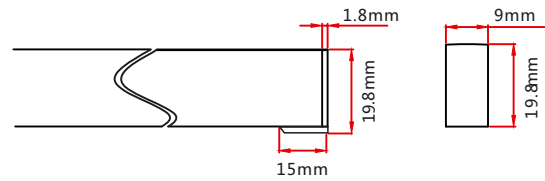

3.2 Clasp Connector

Note: Unless otherwise stated, the tolerance of the connector is $\pm 0.5\text{mm}$.

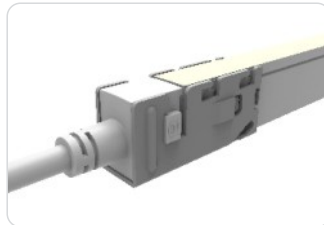

Clasp Front Connector

Connects light to power supply. IP68 DIY connector. Cable length available in 0.3m, 1m, 3m, 5m, 10m, 15m, 20m.

Feed connector*1 (Two-pin)
Silicone gasket*1
U steel plate*1
Anti-skidding clip*1

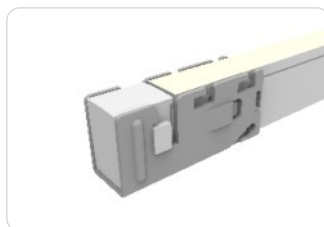
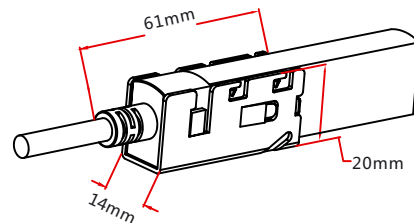

Clasp End Cap

Termination protection of the light. IP68 DIY connector.

Tail plug*1
Silicone gasket*1
U steel plate*1
Anti-skidding clip*1

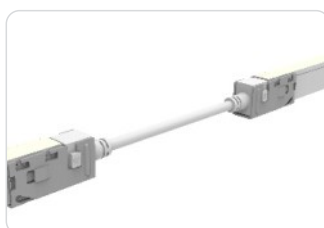
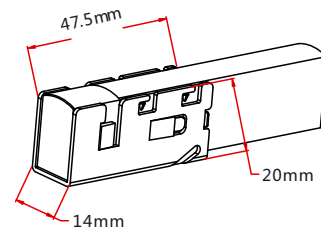

Clasp Jumper

Connects two pieces of lights together with a flexible cable. IP68 DIY connector. L available in 0.3m, 1m and 3m.

Double-end feed connector*1 (Two-pin)
Silicone gasket*2
U steel plate*2
Anti-skidding clip*2

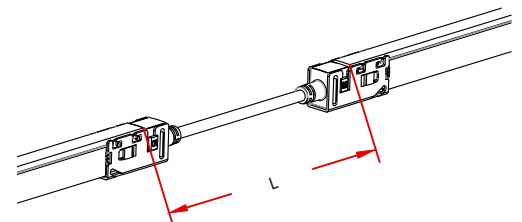



Clasp Power T-feed

Connects two pieces of lights together with a T joint, energized from middle. IP68 DIY connector. L1 and L2 available in 0.3m.

- T joint*1 (Two-pin)
- Silicone gasket*2
- U steel plate*2
- Anti-skidding clip*2

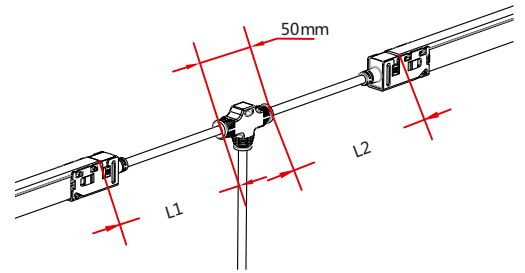

3.3 Snap Connector

Note: Unless otherwise stated, the tolerance of the connector is $\pm 0.5\text{mm}$.

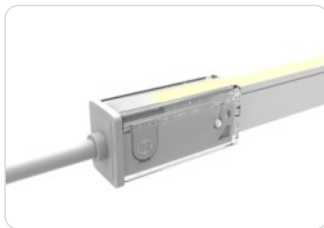

Snap Front Connector

Connects light to power supply. IP68 DIY connector. Cable length available in 0.3m, 1m, 3m, 5m, 10m, 15m, 20m.

- Feed connector*1 (Two-pin)
- Silicone gasket*1
- U steel plate*1
- Anti-skidding clip*1
- PC cover*1

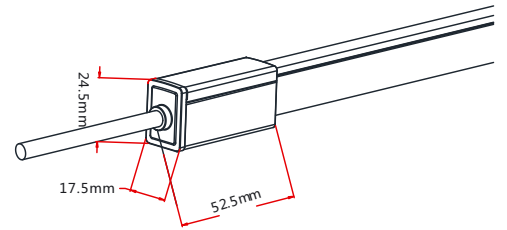

Snap End Cap

Termination protection of the light. IP68 DIY connector.

- Tail plug*1
- Silicone gasket*1
- U steel plate*1
- Anti-skidding clip*1
- PC cover*1

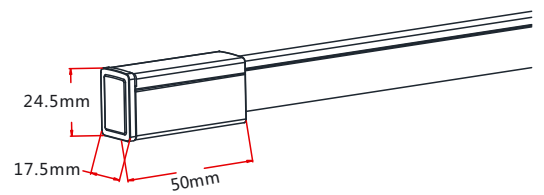

4. Mounting Profile

4.1 Locking Aluminum Profile

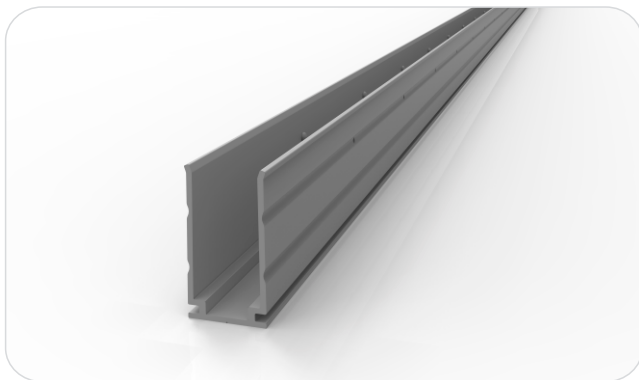

Note: Unless otherwise stated, the tolerance of the profile is $\pm 0.5\text{mm}$.

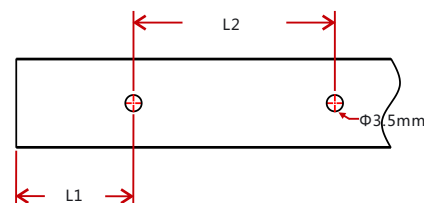
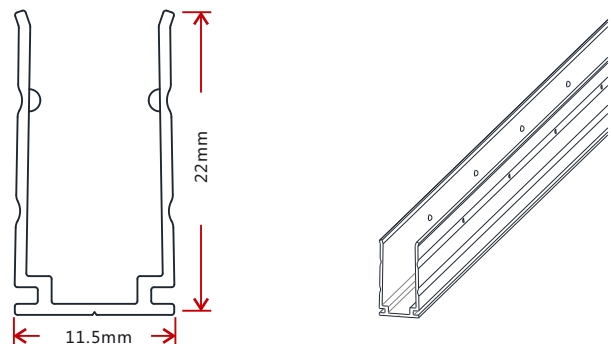

Model	W*H(mm)	Standard Length (mm)	L1 (mm)	L2 (mm)	Screw Hole (mm)	Hole Number	For Product
F10-LA/PL	11.5*22	30	15	/	Φ3.5	2	F10
		50	25	/	Φ3.5	3	F10
		1000	100	200	Φ3.5	5	F10
		2000	100	200	Φ3.5	10	F10

4.2 Plastic Profile

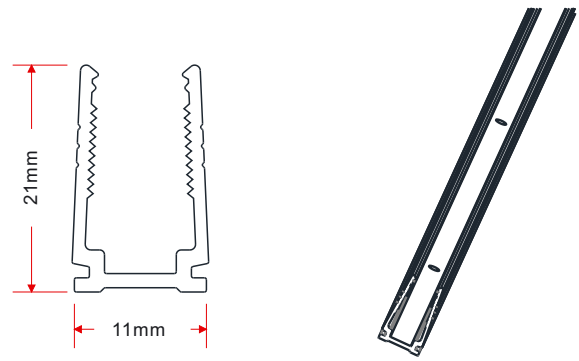
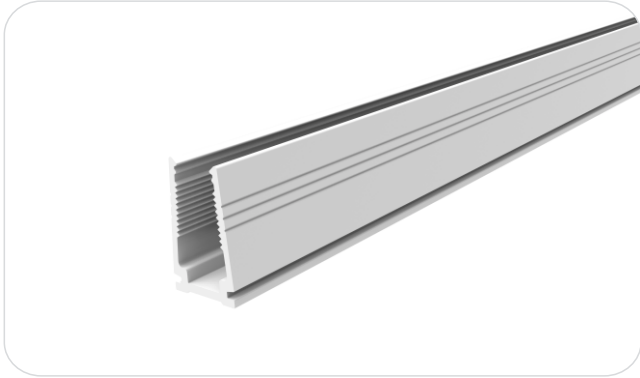

Note: Unless otherwise stated, the tolerance of the profile is ± 0.5 mm.

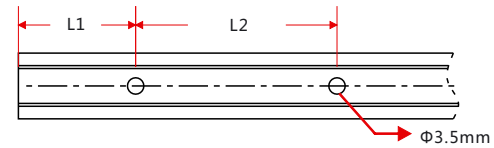

Model	W*H(mm)	Standard Length (mm)	L1 (mm)	L2 (mm)	Screw Hole (mm)	Hole Number	For Product
F10-PC/PL	11*21	300	50	200	Φ3.5	2	F10
		500	50	200	Φ3.5	3	F10
		1000	100	200	Φ3.5	5	F10
		2000	100	200	Φ3.5	10	F10

4.3 Self-locking Aluminum Profile (Using with the Clip)

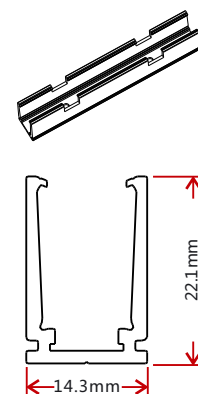
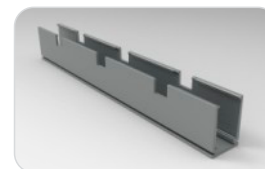
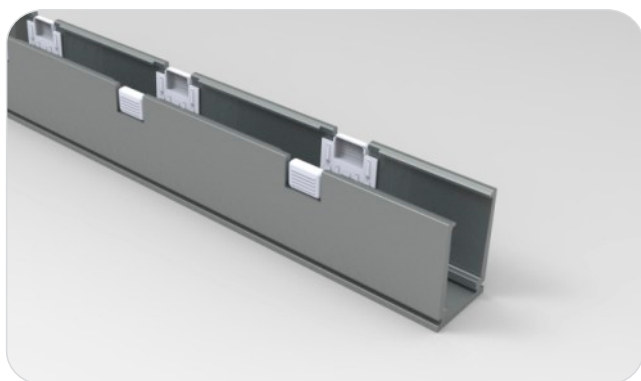

Note: Unless otherwise stated, the tolerance of the profile is ± 0.5 mm.

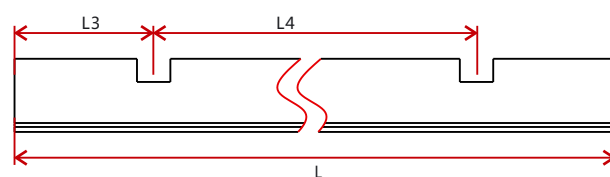
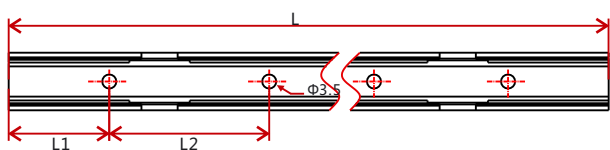

Model	W*H(mm)	Standard Length(mm)	L1(mm)	L2(mm)	L3(mm)	L4(mm)	Hole Screw(mm)	Hole Number	Clip Number
F10-SLA/PL	14.3*22.1	35	17.5	/	17.5	/	$\phi 3.5$	1	1
		50	25	/	25	/	$\phi 3.5$	1	1
		500	100	300	150	200	$\phi 3.5$	2	2
		1000	100	200	150	350	$\phi 3.5$	5	3
		2000	100	200	125	350	$\phi 3.5$	10	6

5. Packaging

Packaging Method

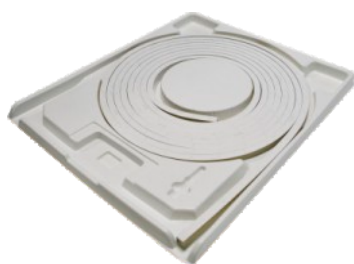

Plastic Plate



White Box



Carton



Packaging Detail

Light Length	White Box Dimension(cm)	Carton Dimension(cm)	Numbers of White Box	Carton Weight(KG)
5m	35*4.2*46	48*37*24	5	6.5
10m	45*4.2*56	58*47*24	5	12
15m	51*5.2*62	64*53*28	5	17
15m	51*5.2*62	64*53*17.5	3	12
20m	61.5*4.2*72	74*63.5*10.5	2	10
30m	68*5.2*79	81*70*12.5	2	14

6. Appendix

6.1 Third-Party Test Report

Testing Item	Testing Organization	Report Number
RoHS	SGS	CANECI202163502 A01
IP68: Screw type	TUV SUD	68.140.12.136.02
IP68: Clasp type	SGS	GZESI40200135301 GZESI40200135401 GZESI40200135501 GZESI40200135701 GZESI40200135801
IPX8: Molding type	SGS	SZESI41200357301 SZESI41200357401 SZESI41200357501
Flame retardant	TUV SUD	68.140.13.068.01
IK08	TUV SUD	68.140.12.171.01
Temperature risen	UL	UL file E360029-Test Record-1 Datasheet
UV: Light	AOV	A002R130308065—1R01
UV: PVC	AOV	A002R130308065—2R01

>>Note: The testing reports and certificates are available from the related official website.

6.2 Reliability Test of Light

Testing Item	Classification	Reference Criterion	Testing Condition/Method	Result
IP Rating Test	IP65/IP68 1m	IEC60529	/	Pass
IK Rating Test	IK08	IEC 62262	Impact energy: 5J	Pass
	Hi-Lo temperature impact	/	-20~70°C, 7 cycles	Pass
	Low temperature storing test	IEC 68-2-1	-20°C	Pass
	High temperature storing test	IEC 68-2-2	60°C	Pass
	High temperature and humidity impact	IEC 68-2-3	/	Pass
Environmental Test	Corrosion resistant test in swimming pool water	/	Free available chlorine: 0.4mg/L	Refer to test report
	Corrosion resistant test in artificial sea water	/	Salt content: 4%	Refer to test report
	Salt spray test	IEC 68-2-11	NaCl solution concentration: 5%	Pass
	Ultraviolet (UV) test	ISO 4892-2	0.76W/m ² , UVA-340nm, 65°C	Refer to test report
Optical Test	Photometric test-ingrating sphere system	ANSI C78.377IES LM79	/	Refer to test report
	Photometric test-goniophotometer system	IES LM 79	/	Refer to test report
Mechanical Test	Bending test	/	Bending diameter: 9cm, 500 times	Pass
	Swing test	/	Swinging angle:-90°~90°, 750 times, lift weight: 300g	Pass
Electrical Test	Electrical insulation test	IEC60598-1	DC500V,2MΩ	Pass

>> Note: Please contact us for related test report.

6.3 Certificate

Certificating Type	Testing Organization	Certificate Serial Number	Report Reference
CE-EMC	SGS	SZEMI41000576803V	SZEMI41000576803
CE-EMC	TUV Rheinland	AE 50274407 0001	17037105 001
CE-LVD	TUV Rheinland	AE 50275368 0001	17036967 001
UL & cUL	UL	20130417-E360029	E360029-20130322

6.4 Figures of Typical Characteristics

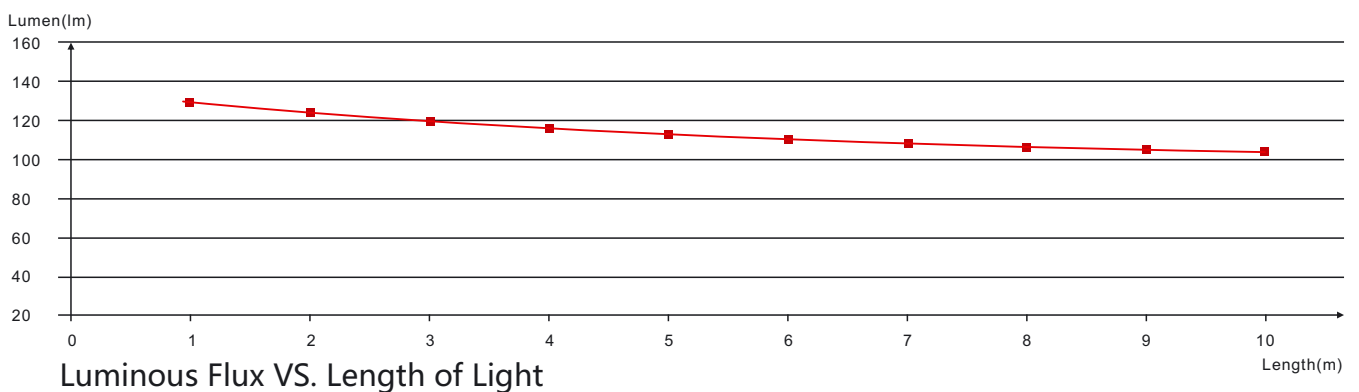
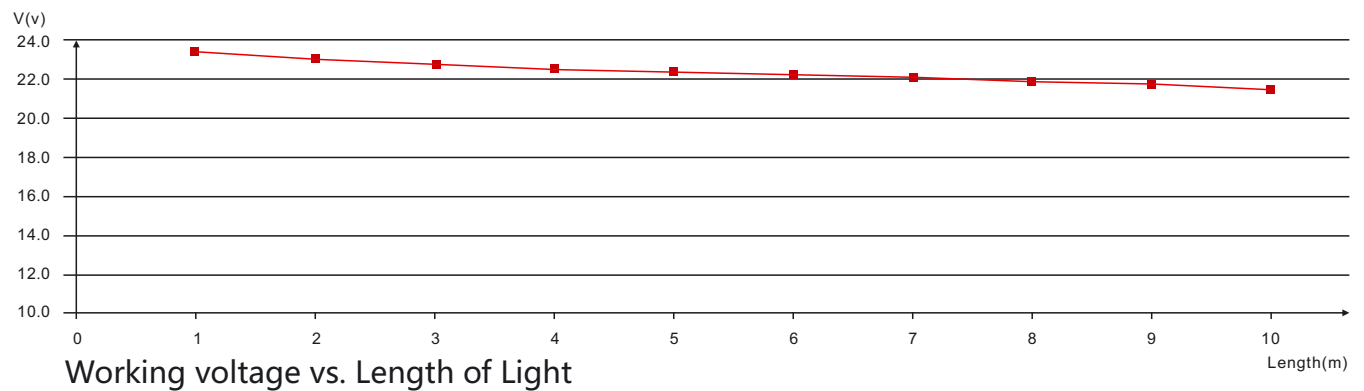
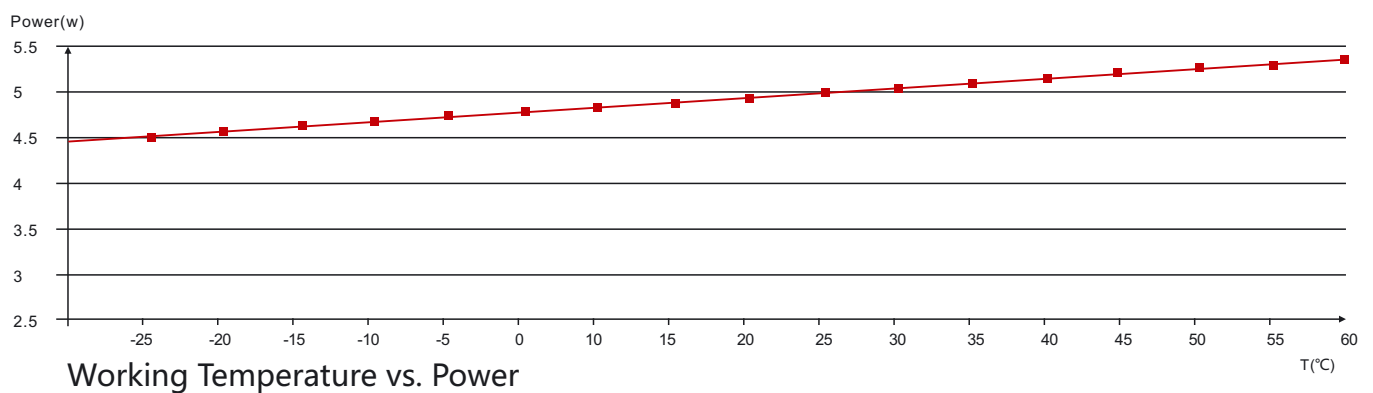

6.5 (X,Y) Chromaticity Diagram

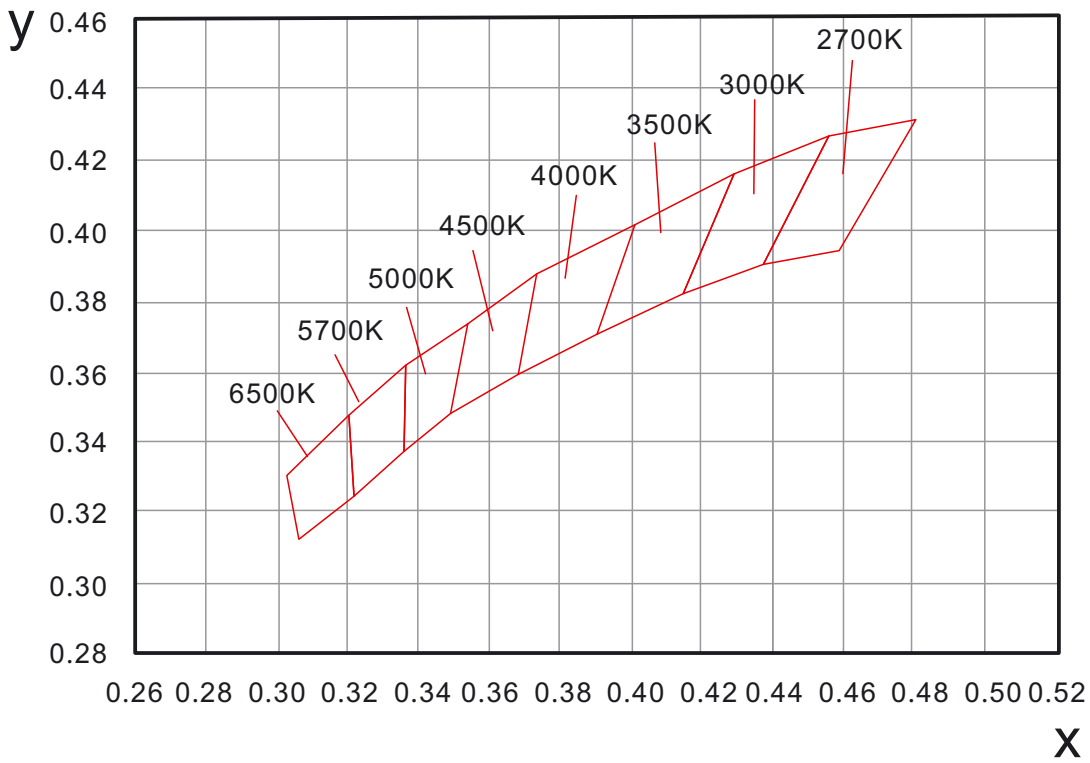

6.6 Wavelength of Color Light

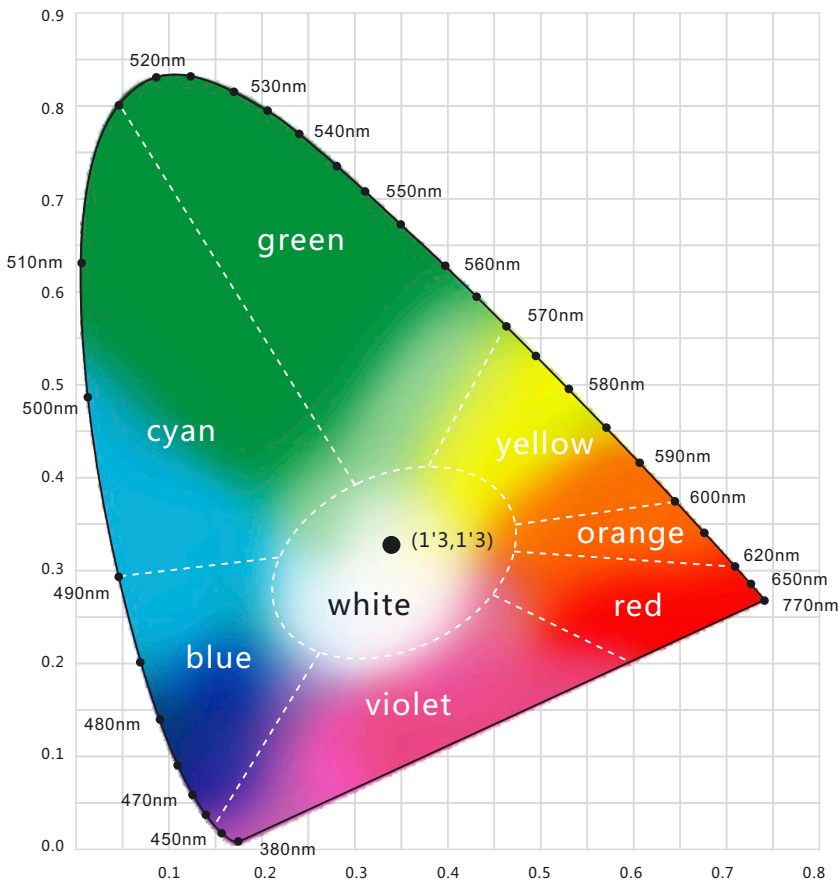

Light Color

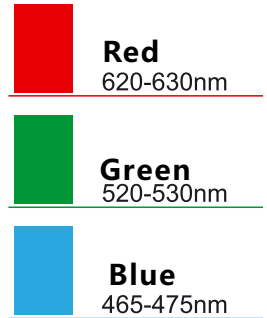

6.7 Loading Chart

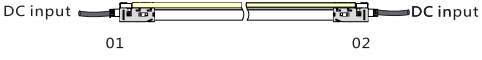
Type.	Rated Power /mtr	Power Supply							
		35w	60w	75w	80w	100w	120w	150w	185w
F10	3.5w	8m	14m	17m	18m	23m	27m	34m	42m
	5w	6m	10m	12m	13m	16m	19m	24m	30m
Energizing way									

Note : 1. These are the light maximum recommended running length subject to selected power supply.
 2. For example: It is recommended to use one 80W power supply loading maximum 18m light (3.5w/m) or maximum 13m light (5w/m) by energizing the light one end.

6.8 Correlated Color Temperature

ANSI STANDARD

Nominal CCT Categories

Nominal CCT	Target CCT and tolerance(K)	Target Duv and tolerance
2700K	2725 ± 145	0.000 ± 0.006
3000K	3045 ± 175	0.000 ± 0.006
3500K	3465 ± 245	0.000 ± 0.006
4000K	3985 ± 275	0.001 ± 0.006
4500K	4503 ± 243	0.001 ± 0.006
5000K	5028 ± 283	0.002 ± 0.006
5700K	5665 ± 355	0.002 ± 0.006
6500K	6530 ± 510	0.003 ± 0.006
Flexible CCT (2700-6500K)	$T^{(2)} + \Delta T^{(3)}$	$D_{uv} T^{(4)} \pm 0.006$

Remark:

- 1). Six of the nominal CCTs correspond to those in the fluorescent lamp specification 2700K,3000K(Warm White),3500K(White),4100K(Cool White),5000K and 6500K(Daylight),respectively.
- 2). T is chosen to be at 100K steps (2800,2900 ,...,6400K), excluding, hose eight nominal CCTs listed in Table 1.
- 3). ΔT is given by $\Delta T = 0.0000108 \times T^2 + 0.0262 \times T + 8$.
- 4). Duv is given by $D_{uv} = 57700 \times (1/T)^2 - 44.6 \times (1/T) + 0.0085$